

# OPENING lights



Most Glazing Applications will benefit from the use of ventilation, giving the user greater control over their internal environment when necessary.

The versatile design of our opening lights enables them to be incorporated into all of our glazing systems with any infill material from 6mm to 28mm thick.

Our opening lights are low profile and offer slender sightlines in comparison to other roof vents available elsewhere.

They have been designed to be operated by a wide variety of Manual, Remote Controlled and Electrical gearing.

Our Top hung range is suitable for installation in both sloping and vertical applications and is generally manufactured to a maximum size of 750mm wide by 1200mm deep.

In a typical roof application, its recommended location will be at the top of the patent glazing, although in certain instances these vents can be positioned in the centre or lower parts of the glazing by using alternative top and bottom panel sections.

Depending on the size of opening light and gearing type used the general maximum

opening size achieved will be in the region of 300mm.

To guarantee water tightness, roof vents must be installed to a minimum of 15°.

**Main section through opening light  
Scale 1:2**

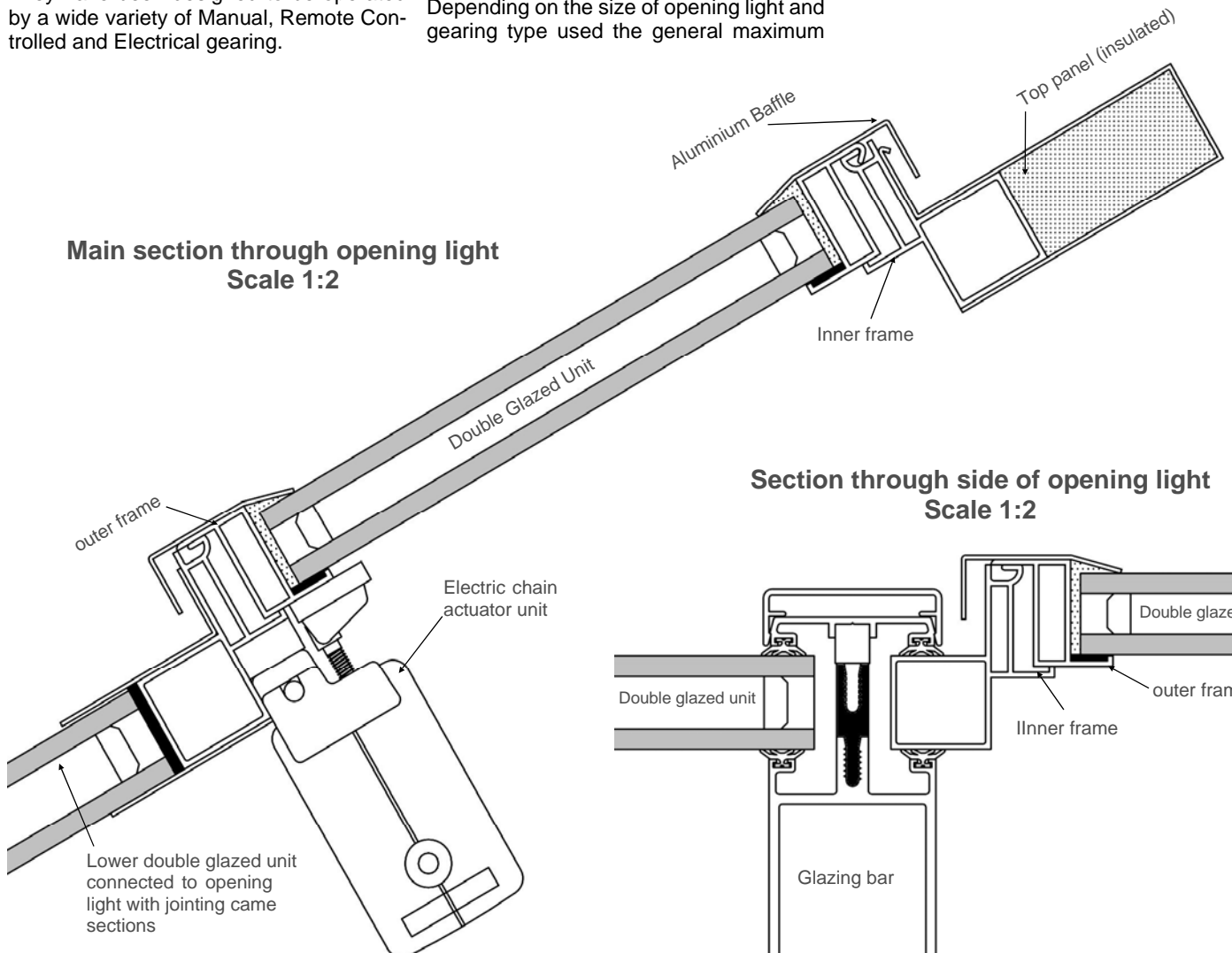

**Section through side of opening light  
Scale 1:2**

